



Now Available  
in Single Reel  
Order Quantities!

## Heyco® Male Pins

For mating Female Pin & Connectors, see pages 8-47 thru 8-49

- **Wide range of diameter and length** combinations for 20 to 10 AWG conductors.
- **Folded Pin design** saves material, **reduces cost**.
- **Hole behind crimp** provides added **strain relief**, or can be cut-off on Assembly Equipment.
- **Conductor crimp ears only**.
- Available only in continuous strip form, regular (left to right) wind.
- **DFARS Compliant**

Dia. in.	PART DATA			PART NO.	APPLICATION TOOLING*					
	Overall Length in.	AWG Range	Material		Die**	Feeds	Tool Packs	Crimp Punch	Anvil	
<b>MP075 Series</b>										
.075	1.00	20-18	Brass	<b>7010</b>	7010UXX5	Left to Right	B300L/B301L	C229	C231	
<b>MP089 Series</b>										
.089	.75	20-18	Brass	<b>7012</b>	7012UXX5	Left to Right	B300L/B301L	C229	C231	
<b>MP093 Series</b>										
.093	.63	20-18	Brass	<b>7002</b>	7002UXX5	Left to Right	B300L/B301L	C229	C231	
	.75	20-18	Brass	<b>7000</b>	7000UXX5					
	.75	16-14	Brass	<b>7008</b>	7008UXX5	Left to Right	B304L/B305L	C230	C232	
<b>MP109 Series</b>										
.109	.63	20-18	Brass	<b>7032</b>	7032UXX5	Left to Right	B300L/B301L	C229	C231	
	.75	20-18	Brass	<b>7030</b>	7030UXX5					
	1.00	20-18	Brass	<b>7034</b>	7034UXX5					
	.63	16-14	Brass	<b>7049</b>	7049UXX5	Left to Right	B304L/B305L	C230	C232	
	.75	16-14	Brass	<b>7047</b>	7047UXX5					

\* Heyco high volume Application Tooling, designed for 3-5 ton presses - see page 8-59.  
Heyco Mini Applicators, designed for 1.5-3 ton bench top presses, are available - see page 8-59.  
\*\* "XX" represents Wire Gauge. Please specify Wire Gauge when ordering.

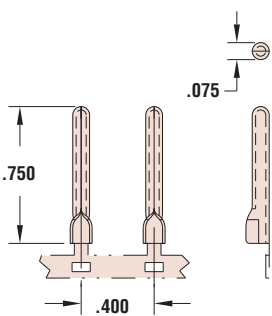

MP075 Series

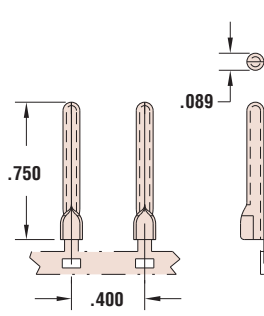

MP089 Series

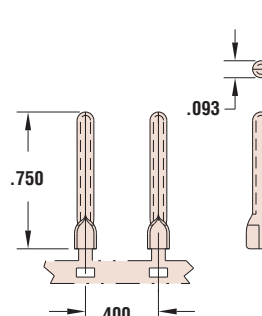

MP093 Series

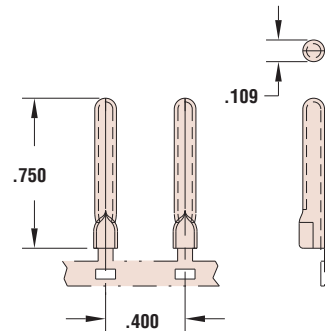

MP109 Series

Quick  
Specs

Materials

Alloy 260 Brass (70% Cu, 30% Zn. Higher Cu content resists dezincification)