



127 Series

- Heavy Duty Terminal Blade.
- 30, 50, and 60 Amp rating.
- Flag type construction for right angle and straight thru plugs.
- Conductor crimp ears only
- DFARS Compliant

128 Series

- Shorter length and smaller crimp ears than the 127 Series and thus lower in cost.
- Conductor crimp ears only.
- DFARS Compliant

375 Series

- a.k.a. “Travel Trailer” terminal blade.
- 30 Amp rating.
- Flag type construction for right angle and straight thru plugs.
- Conductor crimp ears only.
- DFARS Compliant

310 Series

- Shorter in length and narrower than 375 Series.
- 20 Amp rating.
- Flag type construction for right angle and straight-thru plugs features a strain relief “knee” for added pull out protection.
- DFARS Compliant

Padded HD Blades (“PAD”) versus Flat HD Blades:

- Flat Heavy Duty Blades are **front loaded** for overmolding.
- Due to their shaped profiles, Padded Heavy Duty Blades are **side loaded** for overmolding.
- Heyco Heavy Duty **Padded Blades** are **far less expensive** than their Flat counterparts, yet they are functionally equivalent and evaluated and approved by UL for use in UL 817 applications.
- DFARS Compliant

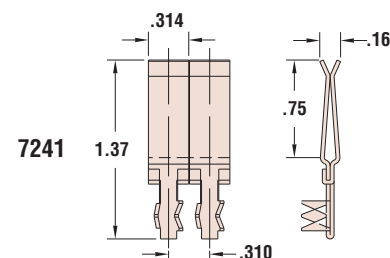

Heyco® Heavy Duty Male Blades for Range and Dryer

See Pages 8-43 & 8-44 for Heavy Duty Ground Pins

PART DATA			PART NO.	APPLICATION TOOLING*			
Type	AWG Range	Material		Die**	Feeds	Crimp Punch	Anvil
127 Series							
.500 Range/Dryer Blade	10-6	Brass	6000	6000SXX5	Bulk	0V23	0V22
		Brass	6004	6004SXX5	Dual		
127-3 Series							
.315 Range/Dryer Blade	10-6	Brass	6010	6010SXX5	Bulk	0V23	0V22
		Brass	6012	6012SXX5	Dual		
127-PAD Series - evaluated and approved by UL for use in UL817 applications							
Padded Range/Dryer Blade	12-8	Brass	6020	6020SXX5	Bulk	0V75	0V74
			6021	6021SXX5	Dual		
127-90 Series							
90° Range/Dryer Ground Blade	10-8	Brass	6002	6002SXX5	Bulk	0W83	0W82
		Brass	6005	6005SXX5	Left to Right Right to Left	0V59	0V58
			6006	6006SXX5		0V46	0V45
127-90-SC Series - Small Crimp							
90° R/D Ground Small Crimp	12-8	Brass	6007	6007SXX5	Bulk	0V92	0V90
128 Series							
.500 R/D Line Blade	12-8	Brass	6015	6015SXX5	Bulk	0V41	0V40
			6017	6017SXX5	Dual		
128-3 Series							
.315 R/D Line Blade	12-8	Brass	6016	6016SXX5	Bulk	0V41	0V40
			6018	6018SXX5	Dual		
128-PAD Series - evaluated and approved by UL for use in UL817 applications							
Padded R/D Line Blade	12-8	Brass	6013	6013SXX5	Bulk	0V74	0V75
			6014	6014SXX5	Dual		
375 & 310 Series							
.375 Line Blade	14-10	Brass	5950	5950SXX5	Bulk	0B95	0B94
			5951	5951SXX5	Dual	0W72	0W74
.310 Line Blade	14-10	Brass	6051	6051SXX5	Bulk	0A03	05C8

* Use the Heyco Standard Applicator Die (indicated by “S” in the Die Part No.), page 8-59.
 ** “XX” represents Wire Gauge. Please specify Wire Gauge when ordering.

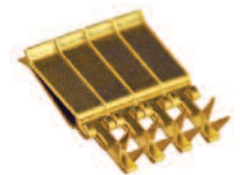

Heyco® Heavy Duty Female Blade

PART DATA			PART NO.	APPLICATION TOOLING*				
Type	AWG Range	Material		Die**	Feeds	Tool Pack	Crimp Punch	Anvil
Wiping Contact	14-12	Brass	7241	7241UXX5	Left to Right	B404L/B405L	C399	C401

* Use the Heyco Universal Applicator Die (indicated by “U” in the Die Part No.), page 8-59.
 ** “XX” represents Wire Gauge. Please specify Wire Gauge when ordering.

Materials	Alloy 260 Brass (70% Cu, 30% Zn. Higher Cu content resists dezincification)
-----------	---

"Stay Connected" with



Power Components

a PennEngineering® Company

Heyco® Heavy Duty Male Blades for Range and Dryer

Heavy Duty Blade Schematics

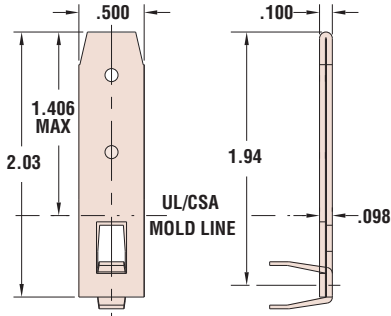

127 Series

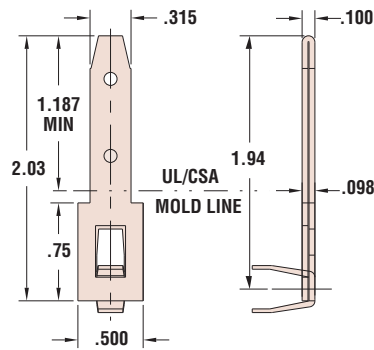

127-3 Series

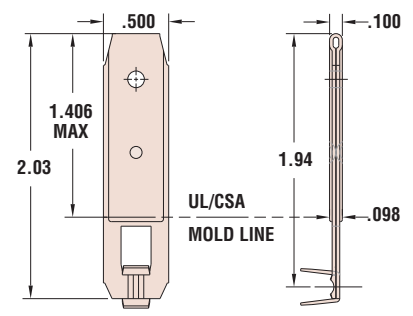

127-PAD Series

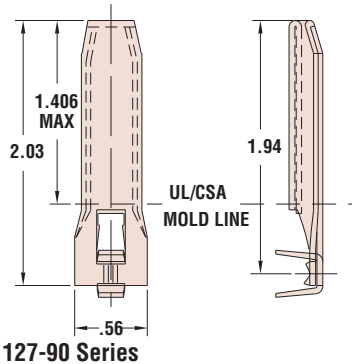
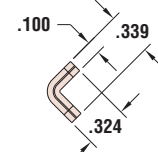
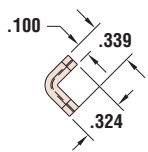

127-90 Series

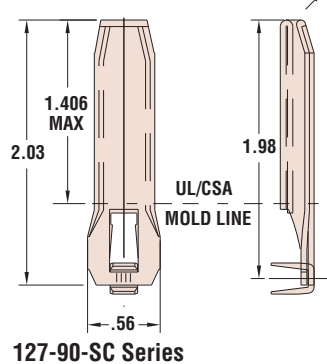

127-90-SC Series

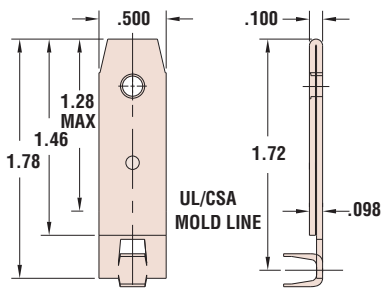

128 Series

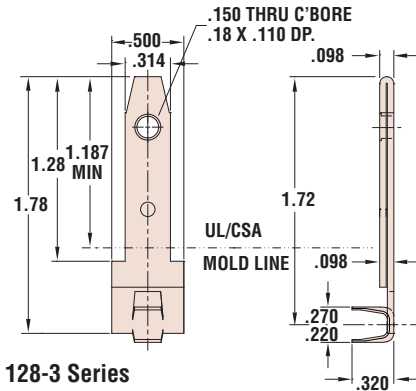

128-3 Series

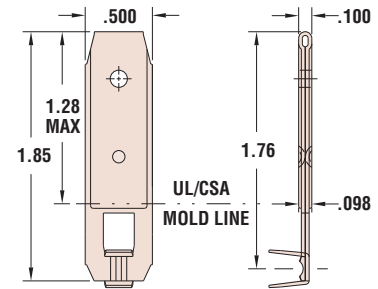

128-PAD Series

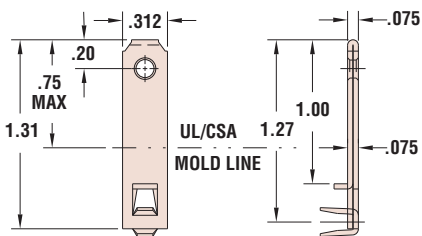

6051 (Bulk)

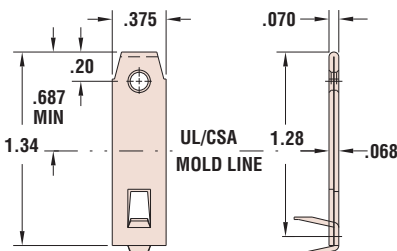

5950 (Bulk)

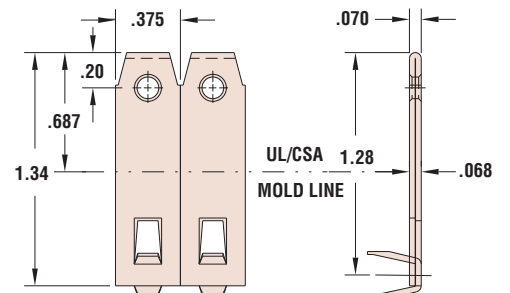

5951 (Strip)